

BackboxCV345

Datasheet Cavity Wall Backbox



Application:

The BackboxCV345 is an easy to install, sound proofing backbox for the Amina Evolution Series speaker models. For use in plasterboard cavity walls (drywalls) and ceilings, the BackboxCV345 creates a sealed enclosure around the back of the speaker utilising a specially designed composite sound proofing layer. The BackboxCV345 is recommended for multispeaker installations where the cavity loading the backbox provides will ensure consistent sound quality from all speaker locations.

Installation:

The BackboxCV345 is designed to be retrofitted into the plasterboard wall or ceiling. Importantly it is fixed to the plasterboard only (not surrounding studwork) which reduces potential energy transfer to the wall/ceiling joists. Our detailed installation guide provides information on how to achieve the correct speaker face alignment for different types of plaster finishes and plasterboard thicknesses. Optional alignment shims are also available.

Sound Proofing Characteristic:

The graph below shows the sound pressure level attenuation of an Amina AIW Evolution Series speaker's rearward output when installed in a BackboxCV345. Over the 150Hz - 5KHz range the rear firing airborne sound pressure is reduced on average by 26dB. It is recommended that additional sound proofing steps are taken if your speakers are installed in a wall or ceiling where bedrooms or other occupied rooms are directly adjacent. The BackboxCV345 cannot stop mechanically induced noise transmission inherent in certain building structures. Please consult Amina for advice.

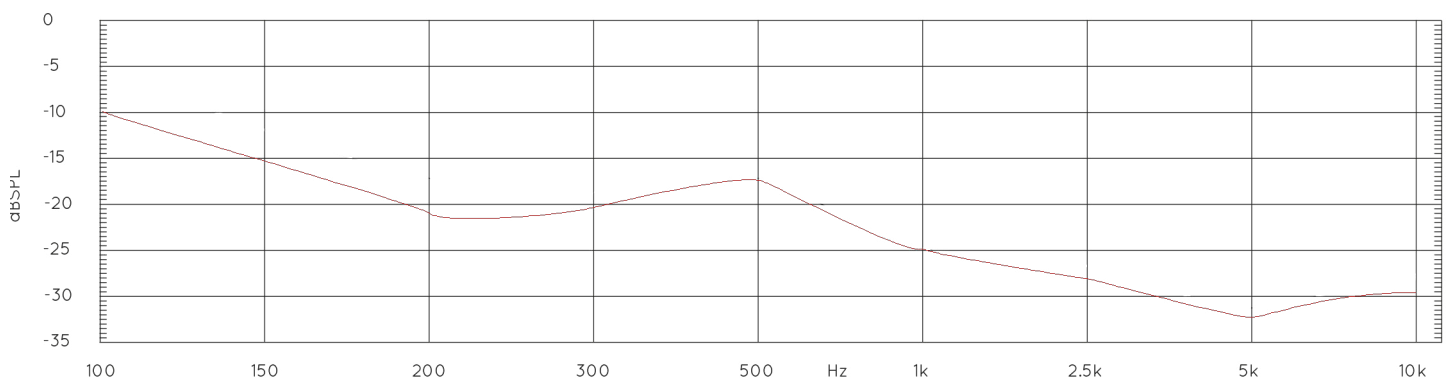

Dimensions

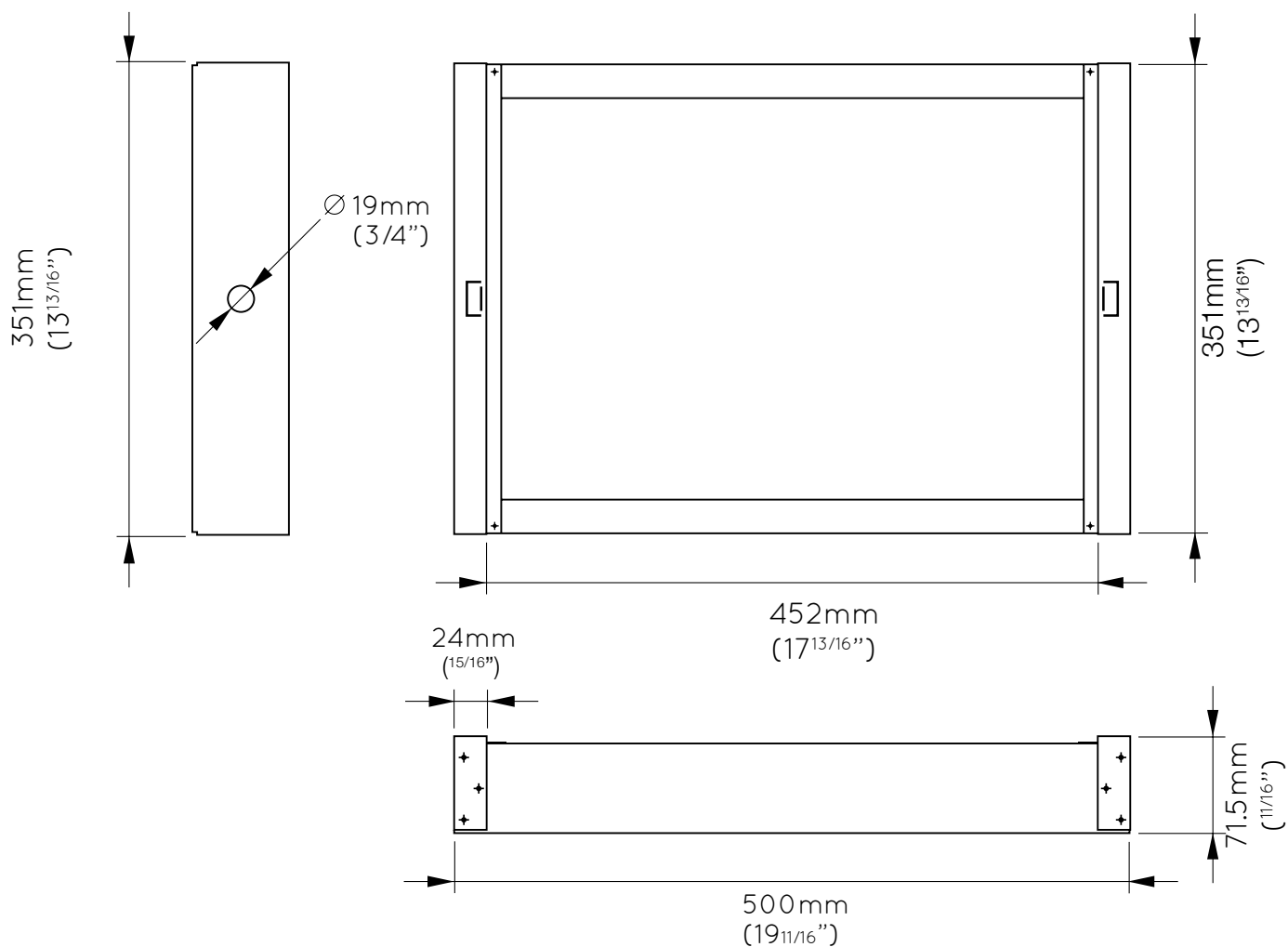

Specifications

Specifications	BackboxCV345
Dimensions	500mm x 351mm x 71.5mm (19 ^{11/16} " x 13 ^{13/16} " x 2 ^{13/16} "
Plasterboard cut-out required	455mm x 350mm
Product weight	2.8Kg (6.2lbs)
Speaker cable entry	Rubber grommet (can be replaced by M20 gland)
Speaker fixing	Use 4x self tapping flangehead screws (supplied)
Wall fixing	Use 8x self tapping drywall screws (supplied)
Minimum cavity depth	75mm (3")
Sound pressure reduction	-26dB on average over 150Hz - 5kHz range

International

Amina Technologies Ltd
 Cirrus House, Glebe Road, Huntingdon
 Cambridgeshire, PE29 7DL, UK
 T: +44 (0)1480 354390
 E: inspired@amina.co.uk
 W: www.aminaco.uk

V 1.5 May 2015 © Amina Technologies Ltd



**Backbox
CV**

US

Amina Technologies Ltd
 P: 1-866 462 6462
 F: 1-888-329 2491
 E: sales@aminatechnologies.com
 W: www.aminaco.uk