

VOID

Hear. Feel. Connect.

voidacoustics.com



Arcline 218

Minimalist Footprint, Maximised Performance

USER GUIDE V2.0

©2022 Void Acoustics Research Ltd.

This user guide is subject to change without notice.
For the latest online version, visit: www.voidacoustics.com

Void Acoustics and the Void logo are registered trademarks of Void Acoustics Research Ltd. in the United Kingdom, USA and other countries; all other Void trademarks are the property of Void Acoustics Research Ltd.

Contents

1	Safety and Regulations	4
1.1	Important Safety Instructions	4
1.2	Limitations	4
1.3	EC Declaration of Conformity	4
1.4	UKCA Conformity	4
1.5	Warranty Statement	4
1.6	WEEE Directive	4
2	Unpacking and Checking	5
3	About	6
3.1	Welcome	6
3.2	Arcline 218 Overview	6
3.3	Key Features	6
3.4	Arcline 218 Specifications	7
3.5	Arcline 218 Dimensions	7
4	Cable and Wiring	8
4.1	Electrical Safety	8
4.2	Cable Considerations for Fixed Installations	8
4.3	Impedance Graph	8
4.4	Arcline 218 Wiring Diagram	9
4.5	Bias Q3/Q5 speakON™	9
4.6	Amplifier Loading Guidelines	10
5	Adjustments	11
5.1	Wheel Removal	11
6	Service	12
6.1	Return Authorisation	12
6.2	Shipping and Packing Considerations	12
7	Appendix	13

1 Safety and Regulations

1.1 Important safety instructions



The lightning flash with an arrowhead symbol within an equilateral triangle is intended to alert the user to the presence of uninsulated "dangerous voltage" within the product's enclosure that may be of sufficient magnitude to constitute a risk of electric shock to persons.



The exclamation point within an equilateral triangle is intended to alert the user of the presence of important operating and maintenance (servicing) instructions in the literature accompanying the appliance.

Safety instructions - read this first

1. Read these instructions.
2. Keep these instructions.
3. Heed all warnings.
4. Follow all instructions.
5. Do not use this apparatus near water.
6. Clean only with a dry cloth.
7. Do not block any ventilation openings. Install in accordance with the manufacturer's instructions.
8. Do not install near any heat source such as radiators, heat registers, stoves, or other such apparatus that produce heat.
9. Do not defeat the safety purpose of the grounding-type plug. A grounding type plug has two blades and a third grounding prong. The third prong is provided for your safety. If the provided plug does not fit into your outlet, consult an electrician for replacement of the obsolete outlet.
10. Protect power cords from being walked on or pinched particularly at plugs, convenience receptacles, and the point where they exit the apparatus.
11. Only use attachments and accessories specified by Void Acoustics.
12. Only use with the cart, stand, tripod, bracket, or table specified by the manufacturer, or sold with the apparatus. When a cart is used, use caution when moving the cart/apparatus combination to avoid injury from tip-over.
13. Unplug the apparatus during lightning storms or when unused for long periods of time.
14. Refer all servicing to qualified service personnel. Servicing is required when the apparatus has been damaged in any way, such as when the power-supply cord or plug is damaged, liquid has been spilled or objects have fallen into the apparatus, the apparatus has been exposed to rain or moisture, does not operate normally, or has been dropped.
15. Since the mains power supply cord attachment plug is used to disconnect the device, the plug should always be easily accessible.
16. Void loudspeakers can produce sound levels capable of causing permanent hearing damage from prolonged exposure. The higher the sound level, the less exposure needed to cause such damage. Avoid prolonged exposure to the high sound levels from the loudspeaker.

1.2 Limitations

This guide is provided to help familiarise the user with the loudspeaker system and its accessories. It is not intended to provide comprehensive electrical, fire, mechanical and noise training and is not a substitute for industry-approved training. Nor does this guide absolve the user of their obligation to comply with all relevant safety legislation and codes of practice. While every care has been taken in creating this guide, safety is user-dependent and Void Acoustics Research Ltd cannot guarantee complete safety whenever the system is rigged and operated.

1.3 EC declaration of conformity

For EC Declaration of Conformity please go to:

www.voidacoustics.com/eu-declaration-loudspeakers

1.4 UKCA marking

For details of the UKCA marking go to:

www.voidacoustics.com/uk-declaration-loudspeakers

1.5 Warranty statement

For warranty statement go to:

<https://voidacoustics.com/terms-conditions/>

1.6 WEEE directive

If the time arises to throw away your product, please recycle all the components possible.



This symbol indicates that when the end-user wishes to discard this product, it must be sent to separate collection facilities for recovery and recycling. By separating this product from other household-type waste, the volume of waste sent to incinerators or land-fills will be reduced and natural resources will thus be conserved.

The Waste Electrical and Electronic Equipment Directive (WEEE Directive) aims to minimise the impact of electrical and electronic goods on the environment. Void Acoustics Research Ltd complies with the Directive 2002/96/EC and 2003/108/EC of the European Parliament on waste electrical and electronic equipment (WEEE) in order to reduce the amount of WEEE that is being disposed of in land-fill sites. All of our products are marked with the WEEE symbol; this indicates that this product must NOT be disposed of with other waste. Instead it is the user's responsibility to dispose of their waste electrical and electronic equipment by handing it over to an approved reprocessor, or by returning it to Void Acoustics Research Ltd for reprocessing. For more information about where you can send your waste equipment for recycling, please contact Void Acoustics Research Ltd or one of your local distributors.

2 Unpacking and Checking

All Void Acoustics products are carefully manufactured and thoroughly tested before being despatched. Your dealer will ensure that your Void products are in pristine condition before being forwarded to you but mistakes and accidents can happen.

Before signing for your delivery:

- Inspect your shipment for any signs of contamination, abuse or transit damage as soon as you receive it
- Check your Void Acoustics delivery fully against your order
- If your shipment is incomplete or any of its contents are found to be damaged; inform the shipping company and inform your dealer.

When you are removing your Arcline 218 loudspeaker from its original packaging:

- Arcline 218 loudspeakers come packaged in a lid and base carton that has a protective sleeve around it; avoid using sharp implements to remove the cardboard to protect the finish
- If you need to place the loudspeaker on a flat surface make sure it is free from debris
- When you have removed the Arcline 218 loudspeaker from the packaging inspect it to ensure there is no damage and keep all original packaging in case it needs to be returned for any reason.

See section 1.5 for warranty conditions and see section 6 if your product needs servicing.

3 About

3.1 Welcome

Many thanks for purchasing this Void Acoustics Arcline 218. We truly appreciate your support. At Void, we design, manufacture and distribute advanced professional audio systems for the installed and live sound market sectors. Like all Void products, our highly skilled and experienced engineers have successfully combined pioneering technologies with groundbreaking design aesthetics, to bring you superior sound quality and visual innovation. In buying this product, you are now part of the Void family and we hope using it brings you years of satisfaction. This guide will help you both use this product safely and ensure it performs to its full capability.

3.2 Arcline 218 overview

Optimised for use in theatres, event spaces and outdoor areas, the Arcline 218 has been developed using extensive Finite Element Analysis (FEA) modelling to offer maximum performance from the smallest footprint. FEA-modelled hyperboloid porting significantly reduces port noise and air distortion, while the advanced internal brace design brings a noticeable weight reduction and increased cabinet rigidity.

Arrayable with the Arcline 118 in multiple configurations, including cardioid, this brings a new level of versatility to the audio arena. Aesthetically-pleasing cable management in cardioid configuration is possible via the front speakON™ chassis. Arcline systems can be arrayed by one person independently and each Arcline product can be cased and transported in multiples, radically reducing setup time.

3.3 Key features:

- Touring 2 x 18-inch low frequency enclosures
- Two high power 18" neodymium transducers
- Front and rear speakON™ chassis
- New ergonomic handle cup design
- Arrayable in multiple configurations, including cardioid
- External dimensions optimised for truck packing
- Hard-wearing textured 'TourCoat' polyurea finish

3 About

3.4 Arcline 218 specifications

Frequency response	30 Hz - 200 Hz ± 3 dB
Efficiency ¹	100 dB 1W/1m
Nominal impedance	2 x 8 Ω
Power handling ²	3000 W AES
Maximum output ³	134 dB cont, 140 dB peak
Driver configuration	2 x 18" LF neodymium
Dispersion	Array dependant
Connectors	Front: 2 x 4-pole speakON™ NL4 Rear: 2 x 4-pole speakON™ NL4
Height	566 mm (22.3")
Width	1316 mm (51.8")
Depth	700 mm (27.6")
Weight	91 kg (200.6 lbs)
Enclosure	18 mm plywood
Finish	Textured polyurethane
Rigging	1 x M20 top hat

¹ Measured in half space ² AES2 - 1984 compliant ³ Calculated

3.5 Arcline 218 dimensions

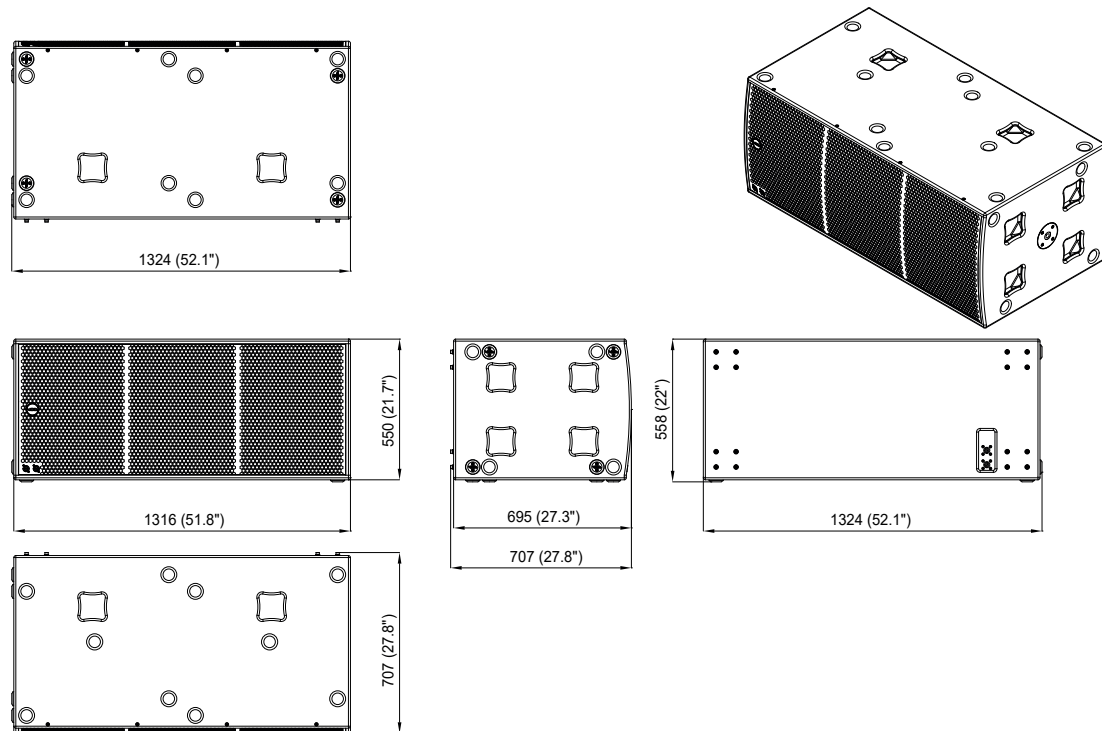

Figure 3.1: Dimensions

4 Cable and Wiring

4.1 Electrical safety



To avoid electrical hazards please note the following:

- Do not access the inside of any electrical equipment. Refer servicing to Void-approved service agents.

4.2 Cable considerations for fixed installations

We recommend specifying installation-grade Low Smoke Zero Halogen (LSZH) cables for permanent installations. The cables should use Oxygen Free Copper (OFC) of grade C11000 or above. Cables for permanent installations should be compliant with the following standards:

- IEC 60332.1 Fire retardancy of a single cable
- IEC 60332.3C Fire retardancy of bunched cables
- IEC 60754.1 Amount of Halogen Gas Emissions
- IEC 60754.2 Degree of acidity of released gases
- IEC 61034.2 Measurement of smoke density.

We suggest using the following maximum copper cable lengths to keep level losses below 0.6 dB.

Metric mm ²	Imperial AWG	8 Ω load	4 Ω load	2 Ω load
2.50 mm ²	13 AWG	36 m	18 m	9 m
4.00 mm ²	11 AWG	60 m	30 m	15 m

4.3 Impedance graph

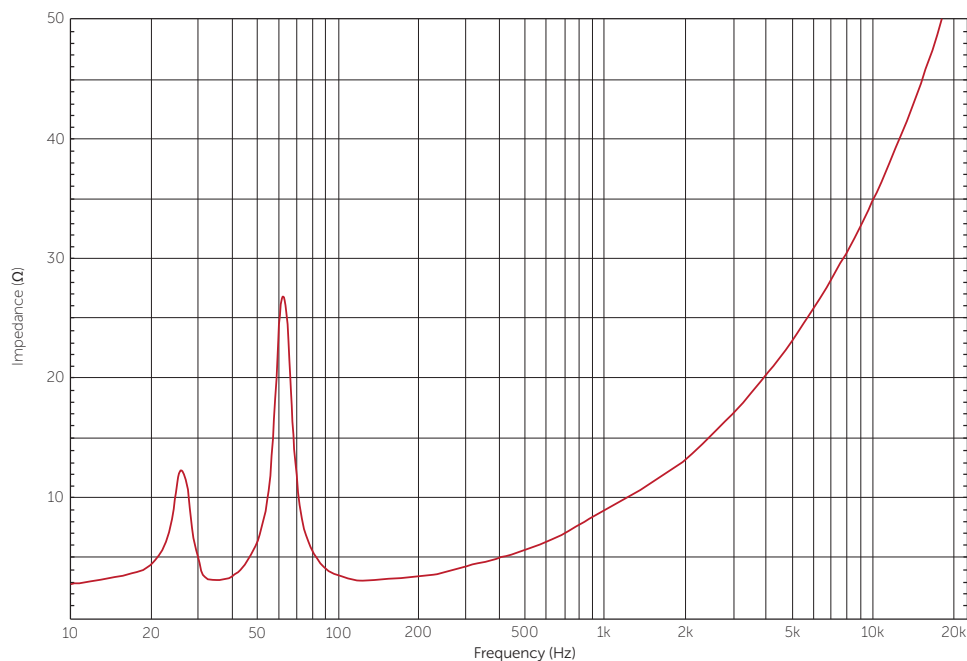

Figure 4.1: Impedance graph

4 Cable and Wiring

4.4 Arcline 218 wiring diagram

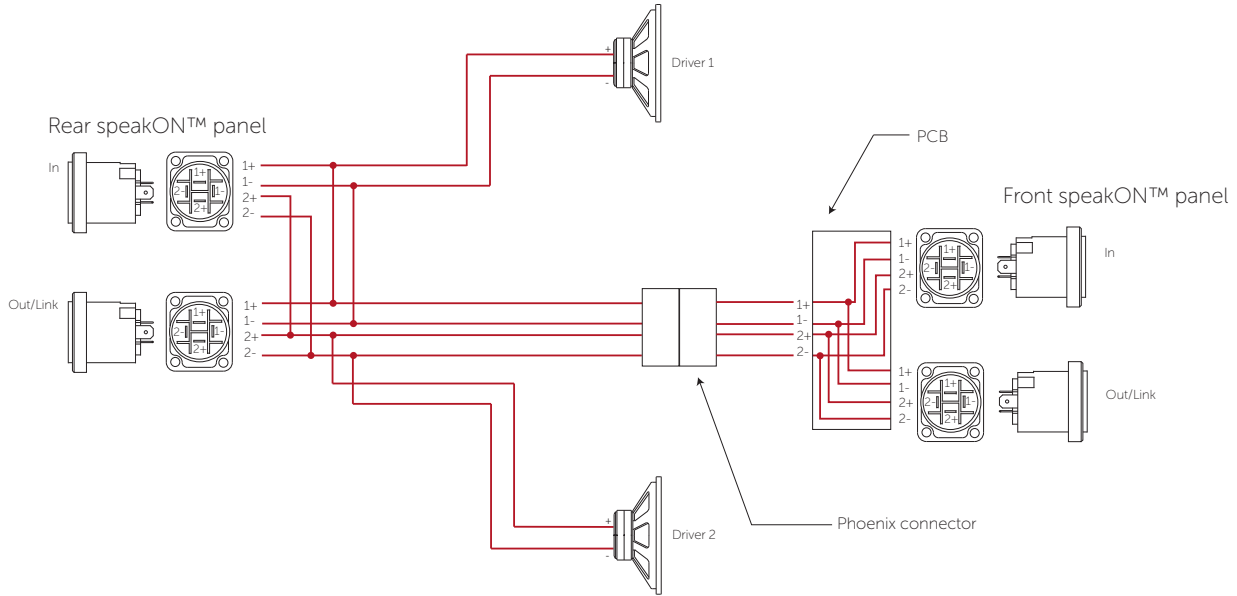

Figure 4.2: Wiring diagram

	speakON™ pins 1+/1-	speakON™ pins 2+/2-
In	Driver 1 (18" LF)	Driver 2 (18" LF)
Out	LF link	LF link

4.5 Bias Q5 speakON™ wiring

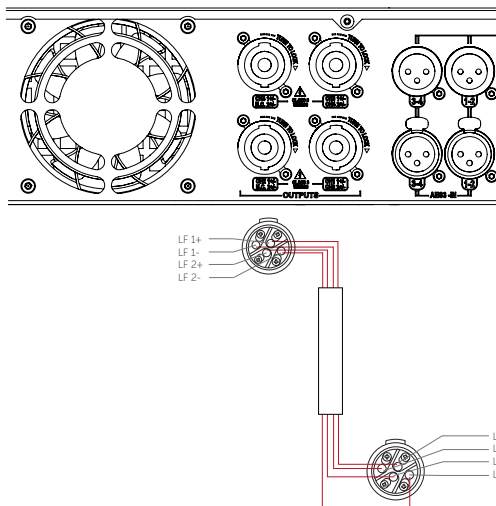

Figure 4.3: Bias Q3

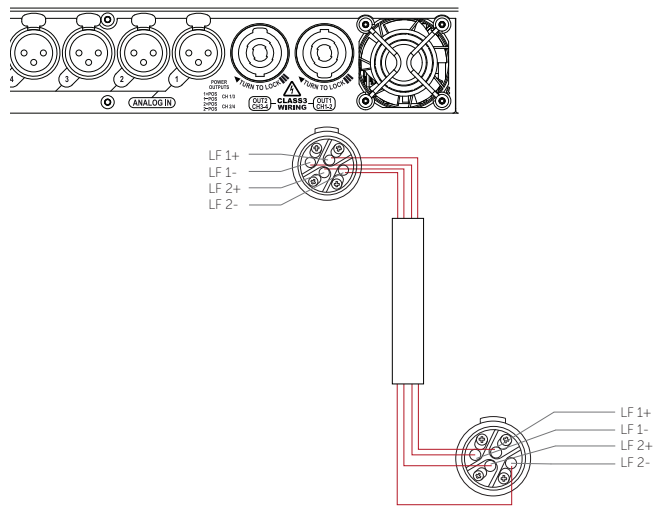

Figure 4.4: Bias Q5

Bias Q5	Output 1 and 2
Output	LF (2 x 18")
Max parallel units	4 (2 Ω load to amplifier)

4 Cable and Wiring

4.6 Amplifier loading guidelines

To maximise the transient response it is recommended that each amplifier not be loaded solely with frequency enclosures. Here we have shown equal loading with Arcline 8. Ensure all amplifier channels are loaded equally and limiters engage correctly.

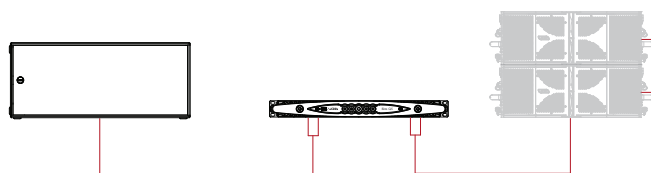

Figure 4.4: 1 x Arcline 218 and 2 x Arcline 8: 8 Ω per channel / 1 amplifier

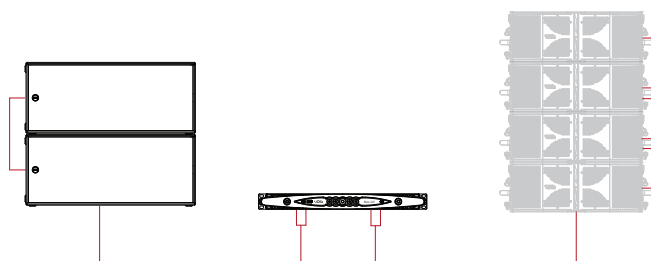

Figure 4.5: 2 x Arcline 218 and 4 x Arcline 8: 4 Ω per channel / 1 amplifier

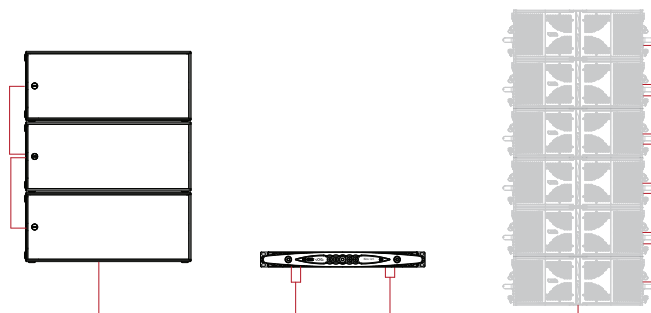

Figure 4.6: 3 x Arcline 218 and 6 x Arcline 8: 2.66 Ω per channel / 1 amplifier

5 Adjustments

To avoid damage when making adjustments please note the following:



- Removing the grille can cause debris to collect within the enclosure, take care to remove anything that may have collected internally
- Do not use impact tools.

5.1 Wheel removal

Step 1:

Remove all four M6 bolts with a 6 mm Allen key.

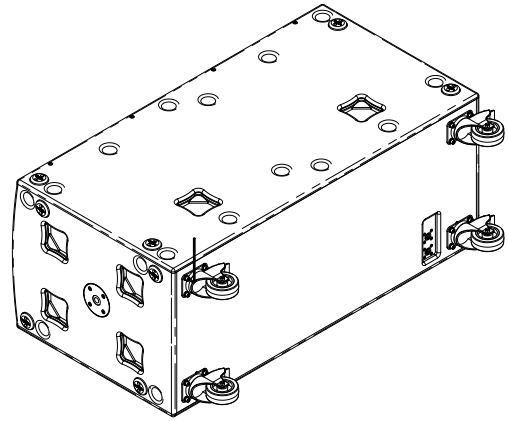

Figure 5.1: Bolt removal

Step 2:

Remove/add the wheels and keep in a safe place. Repeat the process for the other three wheels.

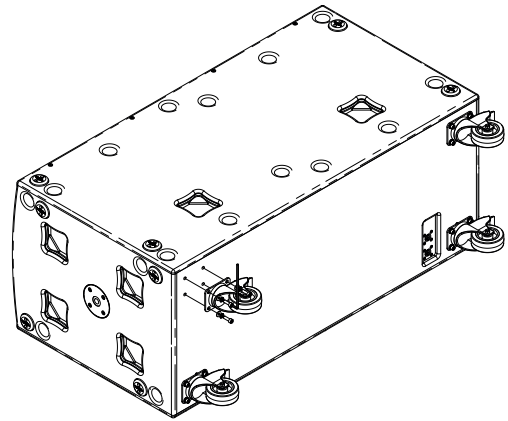

Figure 5.2: Wheel removal

Step 3:

Replace the M8 bolts by hand until finger tight before using hand tools.



Note: Replacing bolts is of particular importance as without them there can be air leakage and detuning.

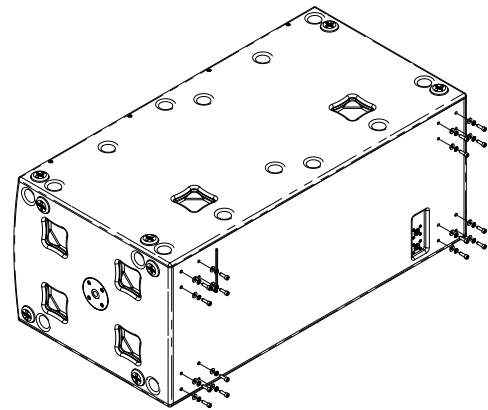

Figure 5.3: Bolt tightening

6 Service

Void Arcline 218 loudspeakers should only be serviced by a fully-trained technician.



No user serviceable parts inside. Refer servicing to your dealer.

6.1 Return authorisation

Before returning your faulty product for repair, please remember to get an R.A.N. (Return Authorisation Number) from the Void dealer who supplied the system to you. Your dealer will handle the necessary paperwork and repair. Failure to go through this return authorisation procedure could delay the repair of your product.

Note that your dealer will need to see a copy of your sales receipt as proof of purchase so please have this to hand when applying for return authorisation.

6.2 Shipping and packing considerations

- When sending a Void Arcline 218 loudspeaker to an authorised service centre, please write a detailed description of the fault and list any other equipment used in conjunction with the faulty product.
- Accessories will not be required. Do not send the instruction manual, cables or any other hardware unless your dealer asks you to.
- Pack your unit in the original factory packaging if possible. Include a note of the fault description with the product. Do not send it separately.
- Ensure safe transportation of your unit to the authorised service centre.

7 Appendix

Architectural Specifications

The loudspeaker system shall be of the bass reflex type using a single hyperboloid port consisting of two high power 18" (457.2 mm) direct radiating low frequency (LF) transducer in a birch plywood enclosure.

The low frequency transducers shall be constructed on a cast aluminium frame, with a treated paper cone, long excursion 101.6 mm (4") voice coil, wound with copper wires on a high quality voice coil former and a neodymium magnet for high power handling and long-term reliability.

Performance specifications for a typical production unit shall be as follows: the usable bandwidth shall be 30 Hz to 200 Hz (± 3 dB) and have a maximum on axis SPL of 134 dB continuous (140 dB peak) measured at 1 m using IEC265-5 pink noise. Power handling shall be 3000 W AES at a rated impedance of $2 \times 8 \Omega$ with pressure sensitivity of 100 dB measured at 1W/1m. The wiring connection shall be via four Neutrik speakON™ NL4 (two front and two rear of the enclosure) two for input and two for loop-out to another speaker, to allow for pre-wiring of the connector before installation.

The enclosure shall be constructed from 18 mm multi-laminate birch plywood finished in a textured polyurea and shall contain fixture points for a pressed, weather-resistant, powder-coated steel grille with foam filter to protect the low frequency transducer. The cabinet shall have four handles (two per side) for efficient manual handling. External dimensions of (H) 550 mm x (W) 1316 mm x (D) 695 mm (21.7" x 51.8" x 27.4"). Weight shall be 91 kg (200.6 lbs).

The loudspeaker system shall be a Void Acoustics Arcline 218.

NORTH AMERICA

Void Acoustics North America

Call: +1 503 854 7134

Email: sales.usa@voidacoustics.com

HEAD OFFICE

Void Acoustics Research Ltd,
Unit 15, Dawkins Road Industrial Estate,
Poole, Dorset,
BH15 4JY
United Kingdom

Call: +44(0) 1202 666006

Email: info@voidacoustics.com



Hear. Feel. Connect.

voidacoustics.com